

Quick Start Instructions

The **ON/OFF switch is on the side**. Slide it forward to turn the Laser beam on. This Laser produces a line rather than a dot. It has both a horizontal and a vertical line. It self-levels so you will see the beam move around for a few seconds until it stabilizes. If you bump the Laser/Stand it will again move around until it re-settles. **NOTE:** There is a limit to the amount it will self-level. If the laser beam is flashing rather than steady you have exceeded this and the beam will not be level. Adjust the base to level.

Major height adjustments are made by loosening the knob on the back of the Laser Bracket, sliding the Laser/Bracket up or down as needed, then retightening the knob. **To make fine height adjustments** use the 4 leveling Screws in the corners of base plate. The laser self-levels. See above if Laser beam flashes.

NOTE: If you prefer 3 point leveling rather than 4 remove the 2 front Leveling Screws and install 1 in the center hole. Remember that a 4 leg system is more stable than a 3 leg one. The choice is yours.

Level 1 scale pad. It doesn't matter which one. This will be your reference. Set up the laser where it can shine on all 4 pads and also the chassis height targets to be set up later (**DO NOT MOVE THE LASER BASE ONCE SET UP** – you can rotate just the laser). Place the Pad Leveler Bar on top of 1 pad, turn the laser on and adjust the laser height so the beam aligns with the silver pad height line on the end of the Pad Leveler Bar. (**NOTE:** The pad itself should be level also. Use the yellow 'bulls eye' level on the top of the pad leveler bar.)

Level the other 3 pads the same way. Place the car on the scale pads. **THIS SYSTEM IS DESIGNED FOR USE WITH CAR ON SCALE PADS. THERE WILL PROBABLY NOT BE ENOUGH ROOM UNDER THE CAR FOR THE TARGETS IF THE CAR IS ON THE GROUND.**

Place the Chassis Height Targets on the bottom of the frame where you normally measure your chassis heights. They are held on with magnets. They should face the laser. With the Laser turned on note the reading on the target. Remember – don't move the laser.

When you are done DON'T FORGET TO REMOVE THE TARGETS FROM THE FRAME. If you let the car down the targets will be damaged.

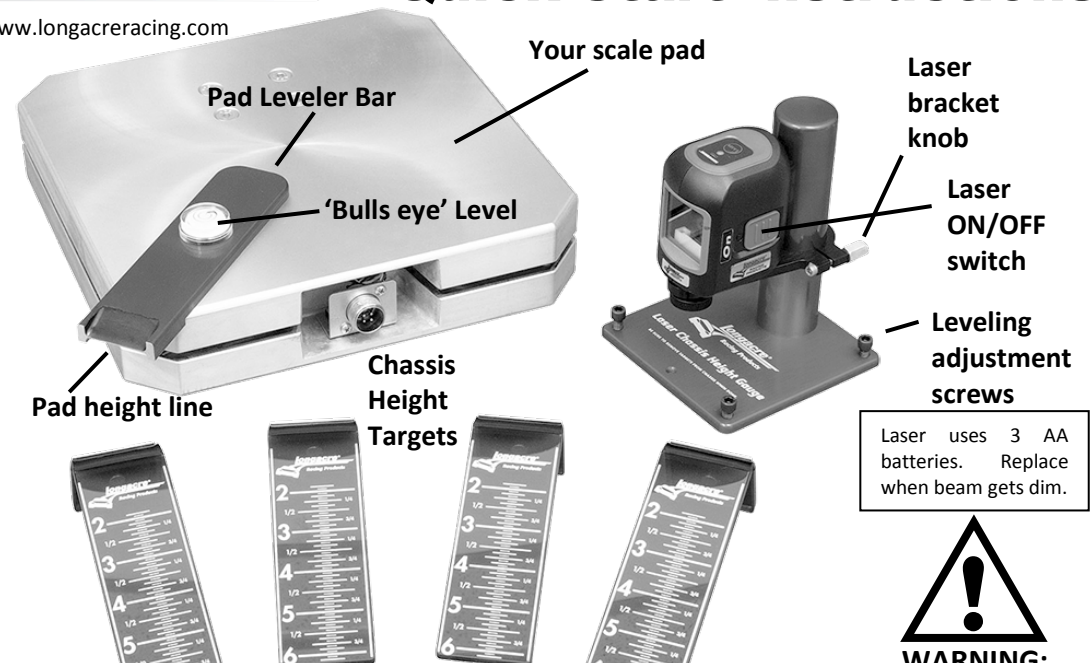

The Targets are made from red transparent Acrylic. This makes the beam much more readable as most of the Laser beam goes on thru the target and only the line shows. Be sure to remove the targets before lowering the car.